

Features and highlights

- Scalable**
 Combine BACtalk control modules (BCMs) to fulfill unique processing and network integration requirements.
- Interoperable**
 BACnet-compliant controller supports BACnet MS/TP network.
- Powerful**
 32 MB RAM, 32-bit processor, and 8 MB of flash RAM provide a fast, reliable platform to run DDC programming and global automation routines.



The Alerton® BCM-MS/TP is a high-performance global controller that supports up to 65 field controllers on a single BACnet MS/TP LAN. MS/TP is a LAN standard designed specifically for BACnet applications using the EIA-485 signaling standard on twisted-pair cabling in a simple bus configuration.

The BCM-MS/TP runs DDC and hosts automation features such as schedules, trendlogs, alarms, optimum start, demand limiting, and tenant activity for the controllers on its MS/TP LAN.

DIN-rail mounting and a ribbon-cable connection to other BCMs make expansion easy. You can add a network or integration option in minutes, which gives you unprecedented flexibility to adapt quickly as your connectivity, integration, processing, and control requirements change.

Technical data

- **Power** No independent power supply required. Conditioned power is provided by the BCM-PWS through a ribbon-cable connection.
- **Data Backup** 7.2V 700mA-h battery in the BCM-PWS provides interim power for orderly shutdown and backup to flash memory in the event of power loss. Real-time clock retains date and time for up to 20 days without power.
- **Memory & CPU** 8 MB flash RAM. 32 MB SDRAM for program execution. 32-bit, high-integration Motorola CPU.
- **Real-time Clock** Onboard real-time clock supports schedule operations, trendlogs, and timed DDC functions.
- **BACnet MS/TP** Removable, header-style screw terminals for 1 BACnet MS/TP (shielded, twisted-pair bus) LAN. Supports 65 VLCs. Configurable from 9.6 to 76.8 Kbps.
- **Max. Dimensions** 6.5" (166mm) H x 1.5" (39mm) W x 5.0" (127mm) D
- **Environmental** 32-131 deg. F (0-55 deg. C). 0-95% RH, non condensing.
- **Ratings**

Listed Underwriters Laboratories for Open Energy Management Equipment (PAZX) under the UL Standard for Safety 916.

EMC Directive 89/336/EEC (European CE Mark).

FCC Part 15, Subpart J, Class A.

- **Software**
Programming interface: BACtalk operator workstation software over BACnet Ethernet.

DDC: VisualLogic® control algorithms execute locally every second. Supports a maximum of 1000 BACnet AVs and 1000 BACnet BVs.

Schedules: Supports a maximum of 80 schedules and 80 calendars.

Alarms: Supports a maximum of 320 alarm setups—system destination and actions individually configurable.

Trendlogs: Supports a maximum of 320 trendlogs to store data point histories for analysis.

Demand limiting: Supports two demand limiter objects, each with 100 loads defined.

Zones and tenant activity logs: Supports 80 zones and 80 tenant activity logs to monitor after-hours energy usage.

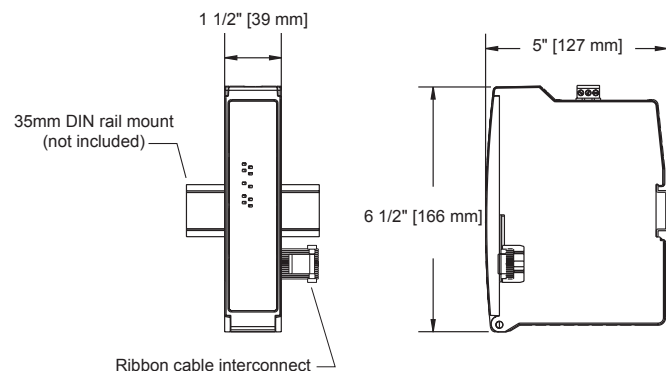

Ordering information

Item number	Description
BCM-MS/TP	BACtalk control module with 1 MS/TP

Specifications subject to change without notice